

WELCOME TO

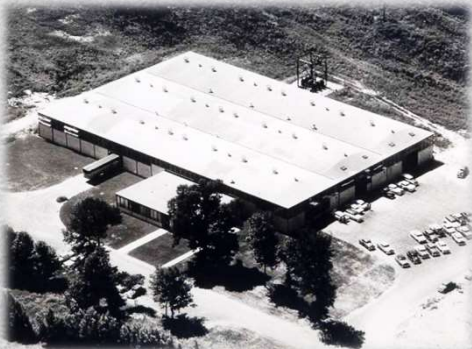

SMALL TUBE PRODUCTS
DUNCANSVILLE, PA U.S.A.



Skilled Producers of Brass and Copper Tubing
Continuing the Excellence Established in 1947



Contents

- **Ownership**
- **STP's Role in the Supply Chain**
- **Statistics / Capabilities**
- **STP Core Competencies**
- **Served Markets**
- **Alloys and Tube Sizes**
- **Tooling**
- **Markets Served**
- **Packaging Forms**
- **Shapes / Fabrication Department**
- **Plant Layout**





Virtus Industries, Inc.

Small Tube Products

- **Purchased by Waybill UK LTD in Nov. 2018**
- **Virtus Industries Inc. – new U.S. corporate entity established Oct .2019**
- **1 of 5 manufacturing facilities owned by this ownership group**
- **Of the 5 facilities, STP remains the most diverse manufacturing facility within the group organizations.**

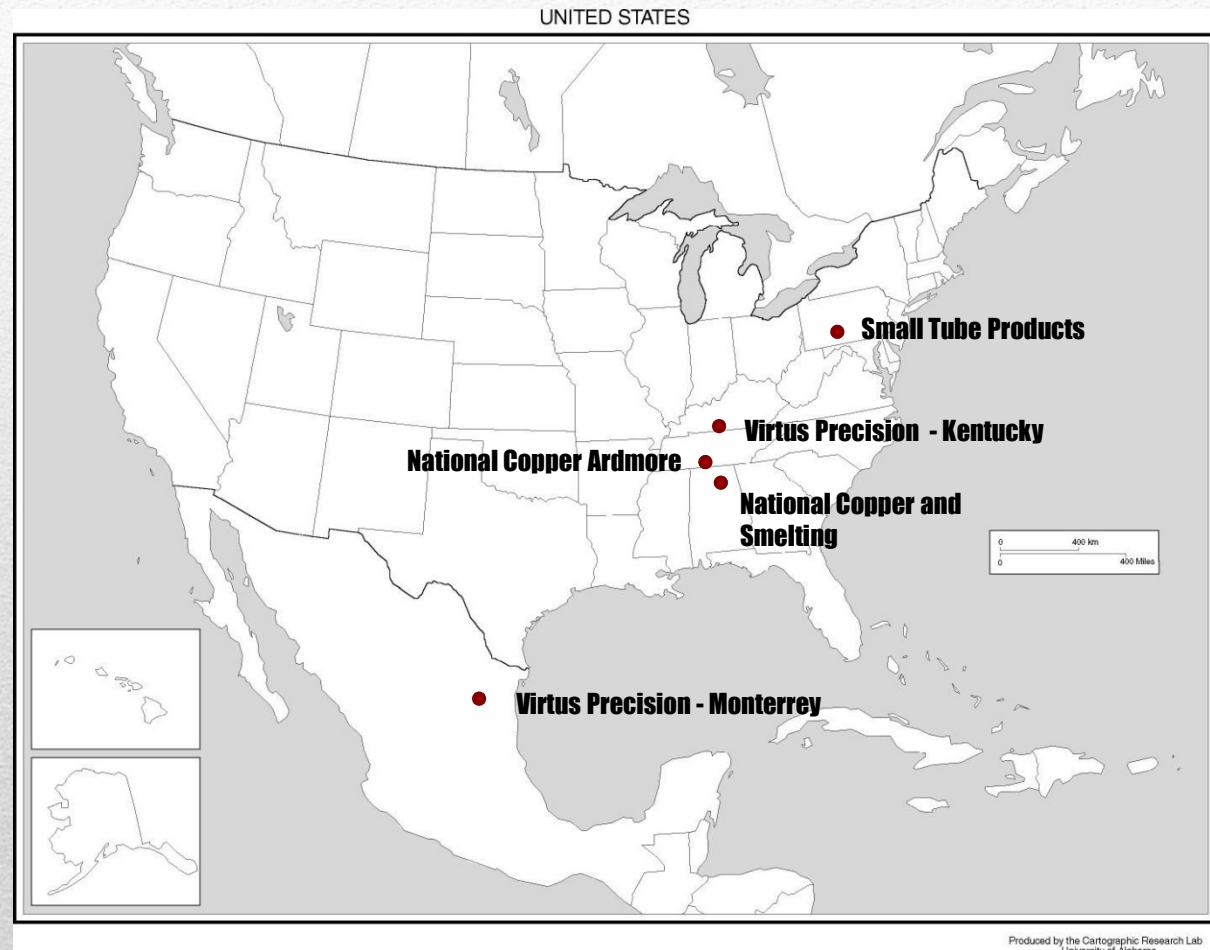



STP's Role in the Supply Chain

Cast and Extrusion

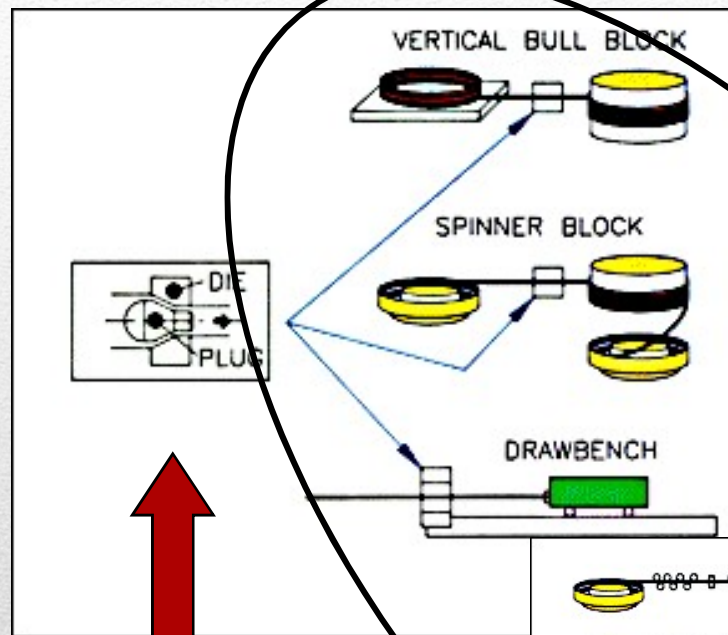
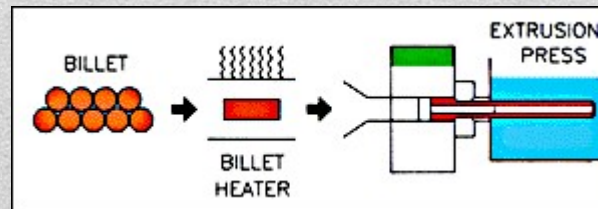
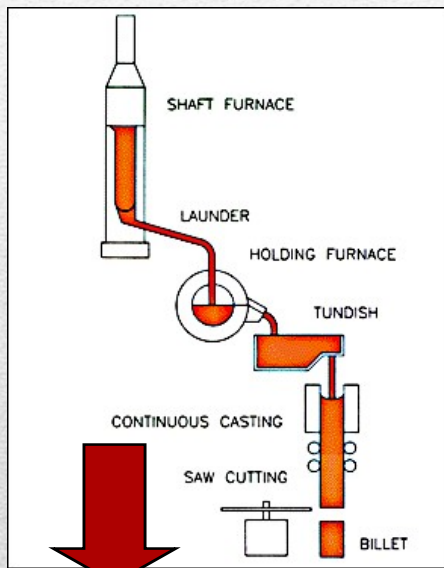

STP's Operations

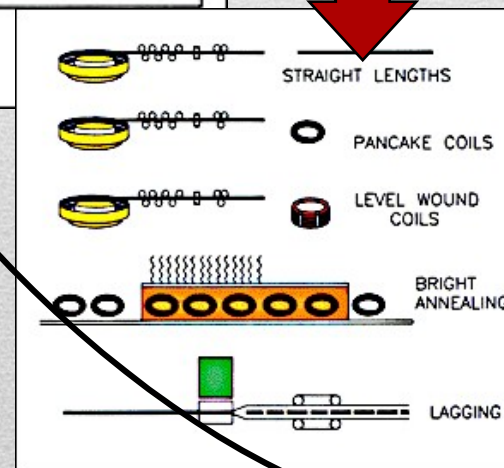



STP's Role in the Supply Chain

Cast and Roll Technology

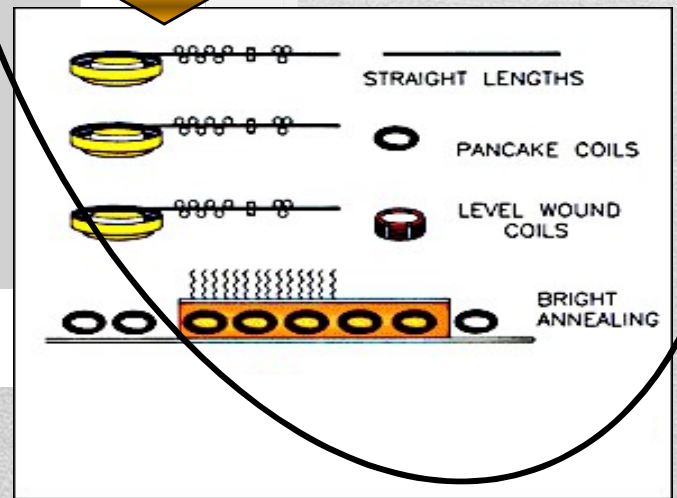
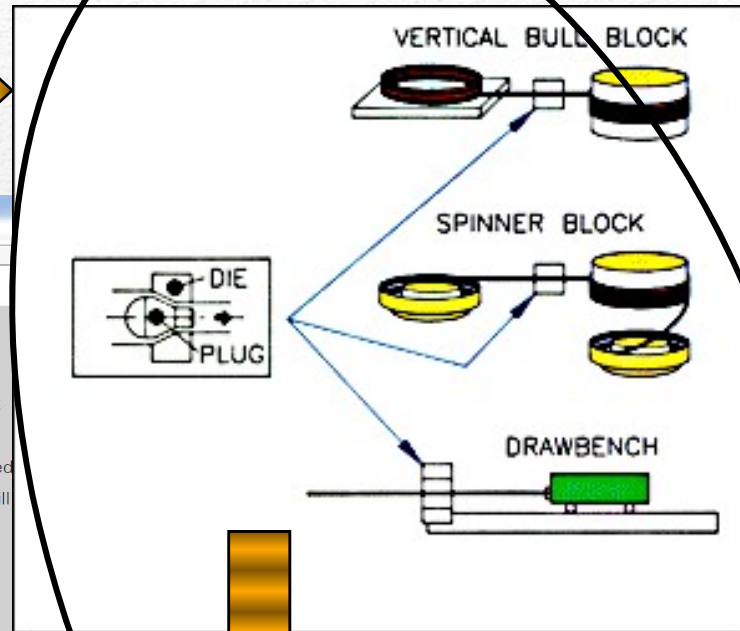
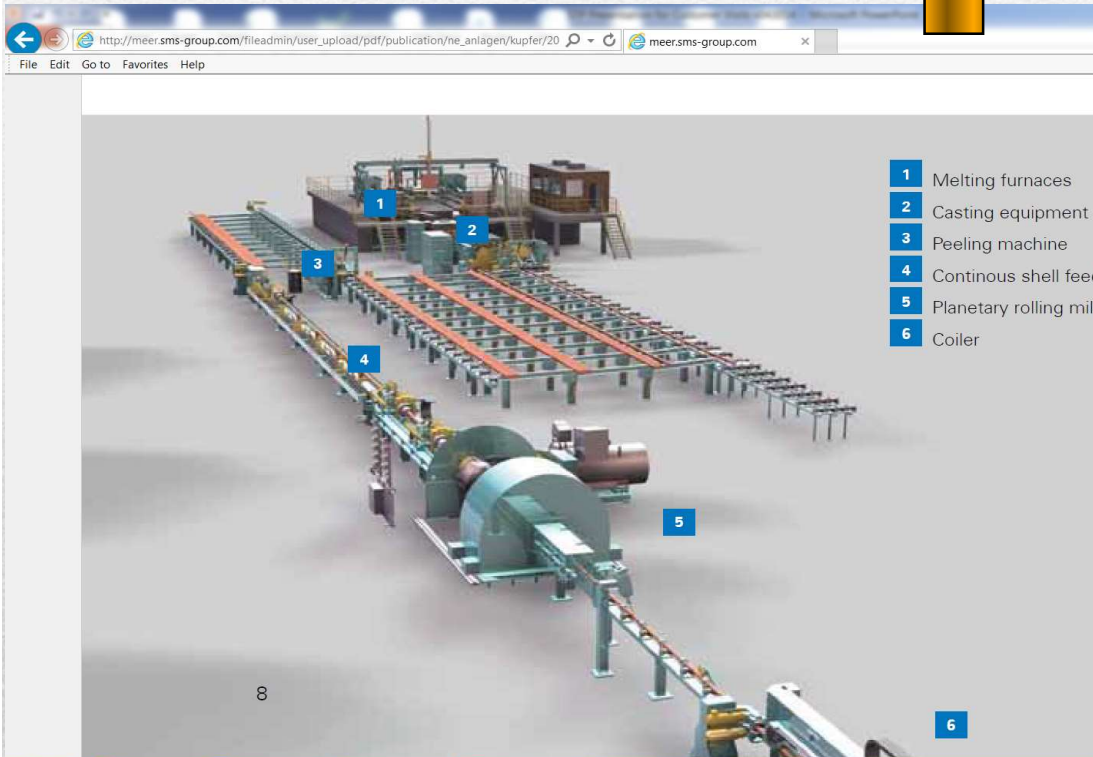
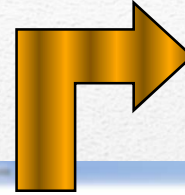



Plant Data / Capabilities

- **Plant Information:**

- 170 employees
- 210,000 sq. ft.
- 3 shifts / 5 day weeks

- **ISO 17025 Accredited Laboratory**

- Dimensional
- Mechanical - *tensile, yield, elongation, hardness*
- Microstructural Analysis - *grain*
- Residual Stress
- Conductivity
- Optical Emission Spectrometry (OES) - *chemical analysis*

- **On-site Customer Service:**

- Servicing customers' needs at the production site
- Gateway for customer to STP's commercial and technical services
- Quotation requirements
- Order Processing / Expediting

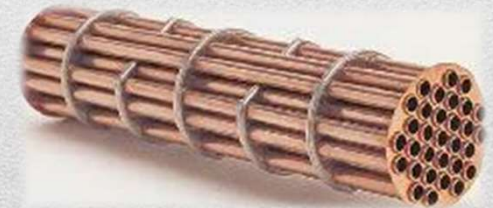



STP Core Competencies

- **Precision redrawing of metals**
 - *22 different copper alloys, 2 Aluminum alloys*
 - *Die profiling expertise*
 - *Precision straightening*
- **Shapes (>1000 architectural combinations)**
- **Short Cut-To-Length**
- **Small lot sizes - 100 lb. minimum**
- **ISO 9001 registered facility**
- **ISO 17025 accredited lab**
- **Non-union, experienced workforce (18 year average tenure)**
- **Continuous Improvement Culture**

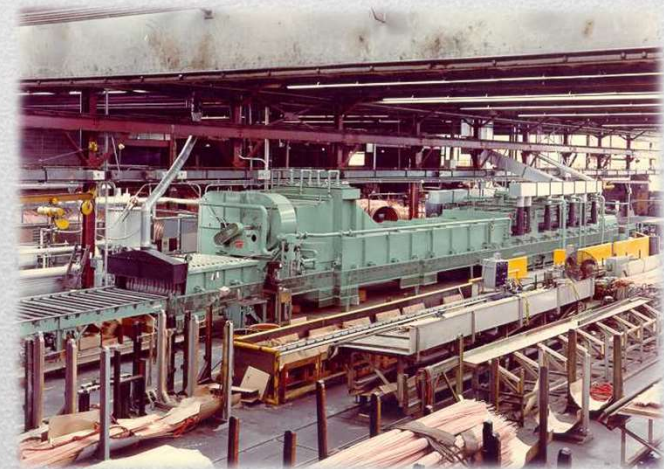

Photos circa 1965



Large Selection of Alloys

(listed by UNS Numbers)

Coppers

- C10100
- C10200
- C12000
- C12200
- C14200 (special order)
- C19400

Copper-Nickel

- C70600
- C71000 (special order)
- C71500

Brasses

- C22000
- C23000
- C26000
- C27000
- C33000
- C33200
- C43500
- C44300
- C68700 (special order)

Phos Bronze

- C51000
- C52100

Nickel Silver

- C74000
- C75200

Aluminum

- A91100
- A93003



Other Alloys may be available upon request

Precision cutting -0.125" to 42 foot lengths



Tube Size Ranges

COILS

ALLOY

- Copper
- Brass
- Copper Nickel
- Aluminum

OD

.040" - .875"

WALL THICKNESS

.005" - .200"

STRAIGHT LENGTHS

ALLOY

- Copper
- Brass
- Copper Nickel
- Leaded Brass
- Phos Bronze
- Aluminum

OD

.040" - 2.625"

WALL THICKNESS

.004" - .367"

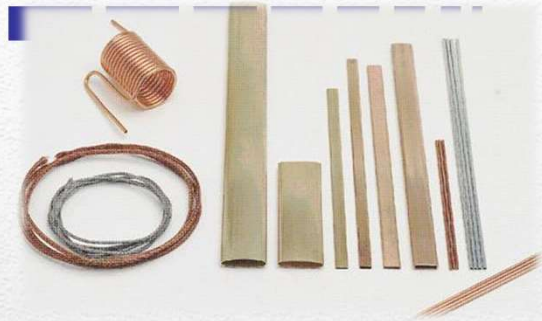



STP In-House Tooling

The essence of STP's quality tubing:

- Tooling expertise
- In-house maintenance and engineering
- Skilled manufacturing people and processes

Extensive training program for tool room personnel

Superior abilities with:

- Die and plug profiling
- Maintenance of Shape Tools
- Saw blade sharpening
- Gage maintenance and design
- Problem Solving for drawing issues
- Tube straightening
- Short cut lengths





The Essence of Tube Drawing

- How *Cold Work* is applied

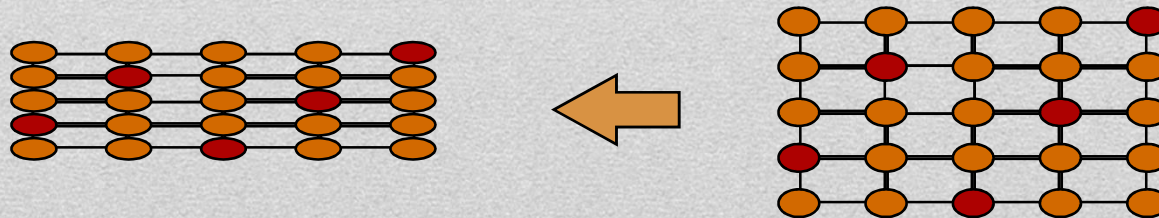
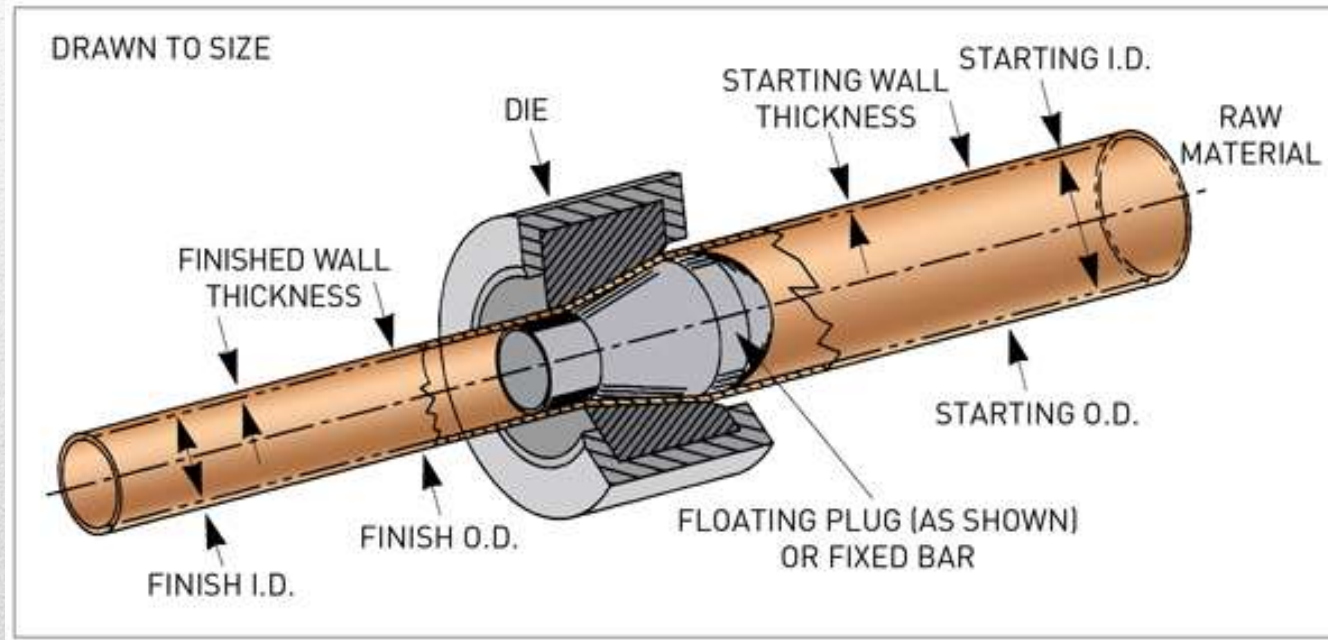



STP Served Markets

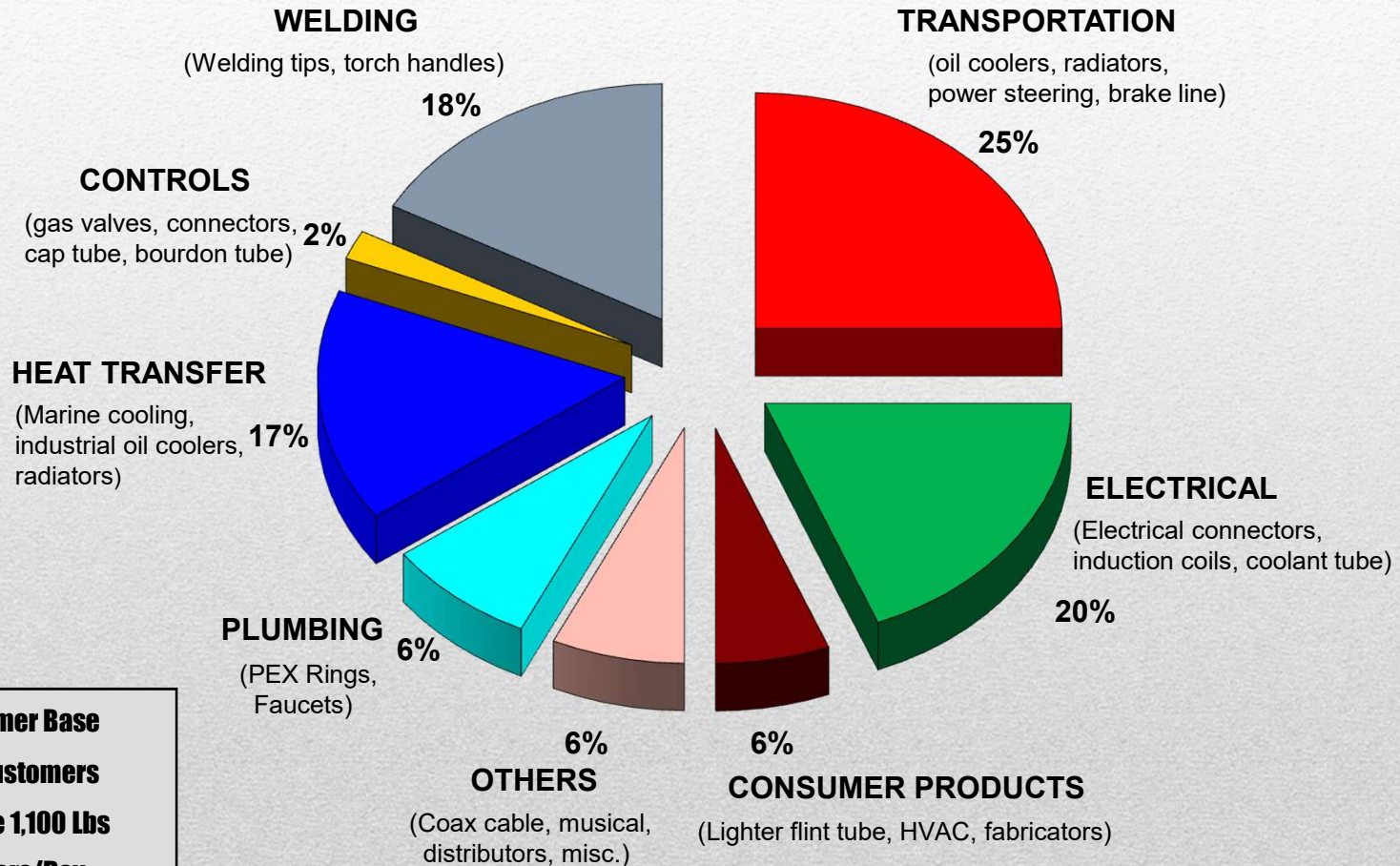

- **Diversified Customer Base**
- **Over 880 Active Customers**
- **Average Order Size 1,100 Lbs**
- **Ship about 60 Orders/Day**



Examples of Shapes

Hourglass/Figure 8



Keyhole



D-Shape



B-Shape



Doghouse

Brushholder

Mailbox

I-Shape

Leak Detector Tube



More than 1,000 different shapes and sizes!

**Oval-Shaped,
Fluted OD**



Square/Round

Square OD and ID



Duplex

Fluted OD/Round ID

Rectangle





Straight Length Packaging

**Wooden End
Cardboard Boxes**



Bundle Pack Options



All Cardboard Boxes



All Wood Boxes





Coil Forms and Packaging

Bunch or Pancake Coils in Octagon-shaped cardboard box



Large Level Wound Coils packed in cardboard box or shrink wrapped



Smaller coil diameter bunch or pancake coils in square cardboard box





Tube Fabrication

- *All Copper Alloys, Brasses, Bronzes, Copper Nickels*
- *Consult mill for production of similar items.*

- **Expanding**
- **Reducing**
- **Counter Boring**
- **Beading**
- **Flaring**
- **Hole Punching**
- **Spinning**

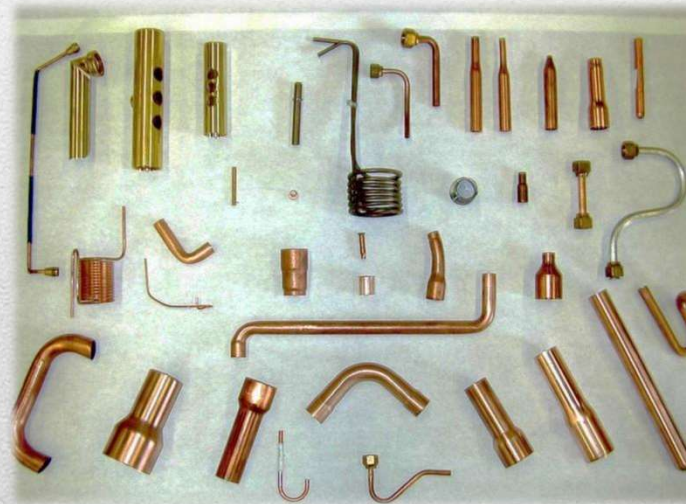

- **Chamfering**
- **Facing**
- **Dimpling**
- **Roll Grooving**
- **Threading**
- **Slitting**
- **Angle Cutting**



Plant Floor Layout

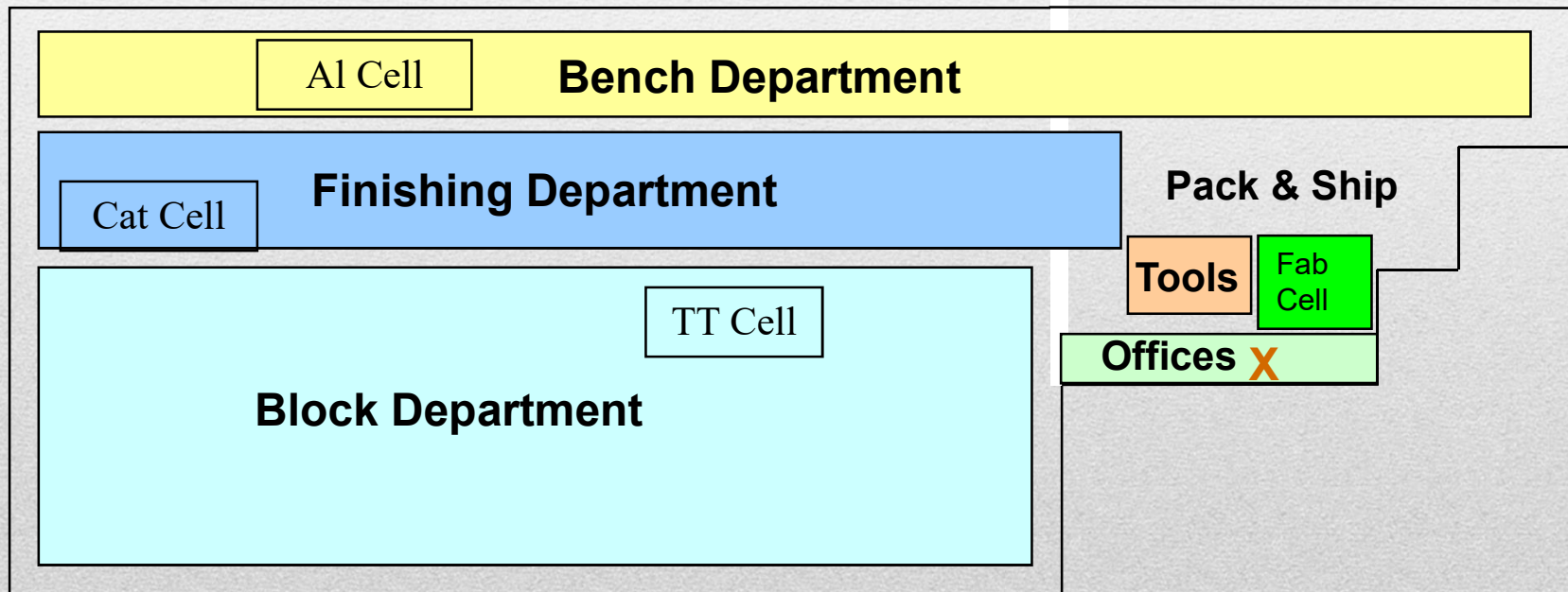



Product Display





End of Presentation

